

(19) World Intellectual Property Organization
International Bureau



(43) International Publication Date
5 March 2009 (05.03.2009)

PCT

(10) International Publication Number
WO 2009/029659 A1

- (51) International Patent Classification:
B21B 27/06 (2006.01)
- (21) International Application Number:
PCT/US2008/074451
- (22) International Filing Date: 27 August 2008 (27.08.2008)
- (25) Filing Language: English
- (26) Publication Language: English
- (30) Priority Data:
60/968,479 28 August 2007 (28.08.2007) US
- (71) Applicant (for all designated States except US): **AIR PRODUCTS AND CHEMICALS, INC.** [US/US]; 7201 Hamilton Boulevard, Allentown, PA 18195 (US).
- (72) Inventors; and
- (75) Inventors/Applicants (for US only): **LIN, Minfa** [US/US]; c/o Air Products and Chemicals, Inc., 7201 Hamilton Blvd, Allentown, PA 18195 (US). **LANYI, Michael, Dennis** [US/US]; c/o Air Products and Chemicals, Inc., 7201 Hamilton Blvd, Allentown, PA 18195

- (US). **PLICHT, Guido** [DE/DE]; c/o Air Products GmbH, Huttenstrabe 50, 45527 Hattingen (DE). **EDWARDS, Robert, James** [US/US]; c/o Air Products and Chemicals, Inc., 7201 Hamilton Blvd, Allentown, PA 18195 (US). **SCHILLAK, Harald** [DE/DE]; c/o Air Products GmbH, Huttenstrabe 50, 45527 Hattingen (DE). **BENNEWITZ, Detlef** [DE/DE]; c/o Air Products GmbH, Huttenstrabe 50, 45527 Hattingen (DE).
- (74) Agent: **NEAGLE, Damon, A.**; Design IP, P.C., 5100 W. Tilghman Street, Suite 205, Allentown, PA 18104 (US).
- (81) Designated States (unless otherwise indicated, for every kind of national protection available): AE, AG, AL, AM, AO, AT, AU, AZ, BA, BB, BG, BH, BR, BW, BY, BZ, CA, CH, CN, CO, CR, CU, CZ, DE, DK, DM, DO, DZ, EC, EE, EG, ES, FI, GB, GD, GE, GH, GM, GT, HN, HR, HU, ID, IL, IN, IS, JP, KE, KG, KM, KN, KP, KR, KZ, LA, LC, LK, LR, LS, LT, LU, LY, MA, MD, ME, MG, MK, MN, MW, MX, MY, MZ, NA, NG, NI, NO, NZ, OM, PG, PH, PL, PT, RO, RS, RU, SC, SD, SE, SG, SK, SL, SM, ST, SV, SY, TJ, TM, TN, TR, TT, TZ, UA, UG, US, UZ, VC, VN, ZA, ZM, ZW.

[Continued on next page]

(54) Title: DISCHARGING CRYOGEN ONTO WORK SURFACES IN A COLD ROLL MILL

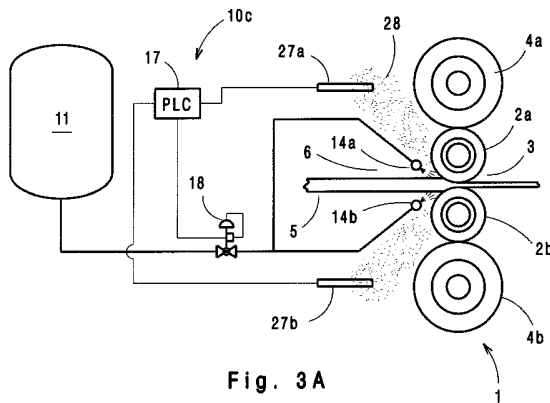

Fig. 3 A

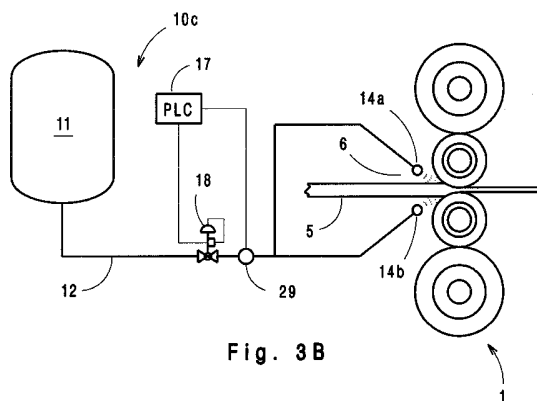

Fig. 3 B

(57) Abstract: The present invention is directed to a method and apparatus for adjusting the amount of cryogen delivered to a mill stand (1) using a non-optical sensor (16a) to measure at least one operating parameter selected from the group consisting of roll stand parameters, rolled product parameters, and cryogen parameters. Output signals are generated by the non-optical sensor and a controller (17) calculates numeric values based on the signals. When the calculated numeric values reach a predetermined set point value that correlates with mill stand temperature, the flow of cryogen is adjusted to disperse a desired amount of cryogenic fluid to said mill stand (1) to control rolling temperature.

WO 2009/029659 A1



(84) **Designated States** (*unless otherwise indicated, for every kind of regional protection available*): ARIPO (BW, GH, GM, KE, LS, MW, MZ, NA, SD, SL, SZ, TZ, UG, ZM, ZW), Eurasian (AM, AZ, BY, KG, KZ, MD, RU, TJ, TM), European (AT, BE, BG, CH, CY, CZ, DE, DK, EE, ES, FI, FR, GB, GR, HR, HU, IE, IS, IT, LT, LU, LV, MC, MT, NL,

NO, PL, PT, RO, SE, SI, SK, TR), OAPI (BF, BJ, CF, CG, CI, CM, GA, GN, GQ, GW, ML, MR, NE, SN, TD, TG).

Published:

- *with international search report*
- *with amended claims and statement*

DISCHARGING CRYOGEN ONTO WORK SURFACES IN A COLD ROLL MILL

5

CROSS REFERENCE TO RELATED APPLICATION

[0001] This application claims the benefit of U.S. Provisional Application No. 60/968,479, filed August 28, 2007, which is incorporated herein by reference as if fully set forth.

10

BACKGROUND

[0002] The present invention is directed to a method and apparatus for controlling the amount of cryogenic coolant applied to the work rolls, roll gap, or rolled product in a mill stand during a cold rolling operation. The amount of cryogen is adjusted in response to a sensor output signal indicative of any one or combination of measured operating parameters including mill stand parameters, rolled product parameters, ambient atmosphere conditions and cryogen parameters.

[0003] Cold rolling is a process used to produce metallic sheet, strip or profiles with specific mechanical properties such as surface finish and specific dimensions within certain dimensional tolerances. In a cold rolling operation, the sheet or strip passes between two counter-rotating work rolls adjusted at a predetermined roll gap setting so that the rolled product is plastically deformed to a required thickness defined by the set roll gap. Cold rolling generates heat in response to the forces required to deform the strip and in response to friction between the work rolls and the strip. The generated heat accumulates in both the work rolls and, if not controlled, may result in temperatures above acceptable cold rolling levels. The acceptable temperatures can vary based on type of metal, strip dimensions, cold rolling parameters and surface finish. Excessive rolling temperatures may lead to (i) changes in the rolled product properties such as surface oxidation, (ii) defects in the strip surface due to the strip adhering to heated roll surfaces and (iii) oxidation of working rolls. Such problems reduce surface quality.

[0004] Past attempts to prevent excessive heat build-up in the mill stand and to reduce friction between the work rolls and the strip include flooding the work rolls and product with coolants and lubricants such as oil, water, or emulsions. However, many of the liquids have negative effects if not quickly removed from the finished product surface. For example, if the metal being cold-rolled is steel, water or aqueous emulsion remaining on the strip can cause oxidation, or rust. In addition, removing oily residue increases production cost and creates

30

environmental problems. For high quality surface finishes, dry rolling is sometimes used to avoid having to deal with the above-mentioned problems. Rolling dry is also sometimes chosen because it will impart a brighter (shinier) finish onto the rolled strip. When rolling dry, production speed must be limited in order to avoid excessive heat build up. In yet other cases, a type of
5 minimum quantity lubrication is used to reduce friction. Even with minimum quantity lubrication, however, in order to maintain the production of strip with good surface finish, it is often necessary to stop the mill rolling to perform periodic cleaning of the working rolls to remove accumulated build-up.

[0005] Recent efforts to find alternative coolants or cleaning methods have led to the use of
10 an inert gas at a lower temperature than the temperature of the rolled product passing through the roll gap. The inert gas may be in either gaseous or liquid form, i.e. a cryogen, or mixed-phase. The lower temperature inert gas provides a cooling alternative to oil, water, or emulsion coolants. Since there is no liquid residue left on the strip when inert gas is used as a coolant in a rolling operation, corrosion problems associated with residual water or emulsion remaining on
15 the strip are prevented. Moreover, use of inert gas provides a cleaning effect for the working rolls and strip surface which, among other benefits, extends the service life of working rolls.

[0006] In applications where a cryogenic coolant is used, overcooling and undercooling are significant issues because of the larger temperature differential between the rolled product and the cryogen. There have been efforts to adjust cryogenic coolant flow rates based on
20 temperature measurements from the roll surface. The temperature measurements are typically taken, however, using optical pyrometers located on the strip entry side of the roll stand, and the flow of cryogenic is controlled to keep the mill temperature within a specified range.

[0007] This approach is problematic because using optical means to measure a temperature change at typical cold rolling temperature ranges is difficult and unreliable. The
25 work rolls are curved or crowned and are highly reflective, providing low and uncertain emissivity for optical pyrometer measurements. In addition, any reflections from extraneous lighting will affect the optical readings within the normal cold rolling temperature range. Condensation caused by the cryogen cooling the air in the space between the optical pyrometer and work roll surface can also cause inaccurate temperature readings.

[0008] Substituting thermal contact sensors for the optical pyrometers is not practical. Measuring work roll surface temperature with contact sensors is difficult to implement and such contact measurements are prone to be unreliable. Use of internal thermocouples to measure
30 work roll surface temperature has been suggested, but would also be unreliable and difficult to implement. For example, positioning internal thermocouples near the work roll surface is

complex from an engineering viewpoint, difficult to achieve, and expensive. Installation of such thermocouples could be simplified by positioning them deeper within the roll, i.e. positioned at a greater distance from the roll surface. However, deeply imbedded thermocouples will lead to an impaired response that generates an inadequate signal for good cooling control.

5 [0009] In addition to the temperature measurement deficiencies of the prior art, accurate, real-time adjustment of the flow rate of a cryogenic coolant using conventional methods is also problematic.

[0010] Therefore, the cryogen cooling control apparatus disclosed in the prior art is impractical and not capable of delivering an accurate, controlled amount of cryogen to a cold roll
10 mill stand. Accordingly, there is a widely-felt need in the industry to provide a cryogen delivery system that provides improved temperature measurement in combination with improved accuracy in the mass flow rate of cryogen delivered to a cold roll mill stand.

[0011] Examples of prior art in this field include German Patent No. DE 199 53 280, PCT Publication No. WO 2006/074,875A1, and U.S. Patent No. 6,675,622.

15

SUMMARY OF THE INVENTION

[0012] In one respect, the invention comprises a method including measuring at least one operating parameter of a cold rolling process, each of the at least one operating parameter being correlated to the thermal conditions of an element of the cold rolling process, and
20 controlling operation of a cryogenic cooling device based at least in part on measurements of the at least one operating parameter.

[0013] In another respect, the invention comprises an apparatus for use with a cold rolling process having at least one sensor, each of the at least one sensors being adapted to measure an operating parameter of the cold rolling process, the operating parameter being correlated to
25 the thermal conditions of an element of the cold rolling process. The apparatus also includes a cryogenic cooling device having an adjustable discharge intensity, and a controller that is configured to receive output signals received from the at least one sensor and is programmed to adjust the discharge intensity of the cryogenic cooling device based at least in part on the output signals received from the at least one sensor.

30 [0014] In yet another respect, the invention comprises a method comprising measuring a load force acting on a roll of a cold rolling process and controlling operation of a cryogenic cooling device based at least in part on measurements of the load force.

BRIEF DESCRIPTION OF THE DRAWINGS

[0015] Figures 1A-1D show various sensors positioned to measure mill stand parameters;

[0016] Figure 1E shows a combination of at least two different sensors positioned to measure mill stand parameters;

5 [0017] Figures 2A-2D show various sensors positioned to measure rolled product parameters;

[0018] Figure 2E shows a combination of at least two different sensors positioned to measure rolled product parameters;

[0019] Figures 3A-3B show various sensors positioned to measure cryogen parameters;

10 [0020] Figure 3C shows a combination of at least two different sensors positioned to measure cryogen parameters;

[0021] Figure 4A shows sensors positioned to measure mill stand parameters in combination with sensors positioned to measure rolled product parameters; and

[0022] Figure 4B shows a combination of sensors positioned to measure mill stand
15 parameters, sensors positioned to measure rolled product parameters, and sensors positioned to measure cryogen parameters.

DETAILED DESCRIPTION OF THE INVENTION

[0023] The use of cryogenic coolants, namely liquid nitrogen or other suitable liquefied or
20 solid gas, eliminates problems associated with earlier coolants such as water, oil, and emulsions. However, cryogenics are also problematic in that it is essential to maintain accurate control over the amount of cryogen delivered to the work roll surfaces and rolled product surfaces (hereinafter referred to as working surfaces), so that under-cooling or over-cooling is avoided. In the past, water-based and oily coolants were simply flooded into the region of the
25 roll gap and the over-supply of coolant provided a self-regulating, steady-state thermal condition in the work surfaces, producing desired properties in the final rolled product.

[0024] When the coolant is a cryogen, however, it is not possible to self-regulate work
surface temperature by flooding with an over-supply of coolant because excess amounts of
cryogen will create uncontrolled operating conditions. For example, excess amounts of cryogen
30 create large vapor clouds that obscure visibility in the mill stand, and possible oxygen deficient atmospheres within the mill operating area. In addition, over-cooling adversely affects finished product quality due to a reduction in the plasticity of the rolled product. Over-cooling also

produces excessive amounts of condensation on the sheet or strip surfaces creating surface defects or corrosion problems. Therefore, accurate control over the amount of cryogen delivered to the mill stand is essential to avoid the above problems.

[0025] As explained above, however, existing attempts to base cryogenic flow rates on temperature readings taken by pyrometers has proven inaccurate and impractical. The present invention utilizes operating parameters other than direct temperature measurements of the surface of the rolled material, individually and/or in combination, to determine desired cryogen flow rates. Many of the measured parameters are correlated to the temperature of the rolled material. It should be understood that parameters that are correlated to the temperature of the rolled material exclude direct measurement of the temperature of the rolled material.

[0026] As used herein, the term "cryogenic cooling device" is intended to mean any type of apparatus or device which is designed to discharge or spray a cryogenic fluid (either in liquid, mixed-phase, or gaseous form). Examples of cryogenic cooling devices include, but are not limited to, cryogenic spray bars, individual cryogenic spray nozzles, and devices containing arrays of cryogenic spray nozzles.

[0027] Referring to Figures 1A through 1D, various cryogen delivery systems 10a for a mill stand 1 are shown. Each cryogen delivery system 10a comprises a different sensor positioned at a suitable location for measuring operating parameters for the cold rolling process. In each embodiment, mill stand 1 includes a pair of opposed work rolls 2a and 2b set to a predetermined roll gap 3, preferable but not necessary backup rolls 4a and 4b that maintain a constant distributed roll force on the work rolls and rolled product 5 and a strip entry side 6 that receives incoming product.

[0028] Referring to Figure 1A, the cryogen delivery system 10a includes a storage tank 11 that contains a supply of cryogen such as liquid nitrogen or other liquefied gas at a temperature of -70° C or lower. In the preferred embodiments, the pipe or conduit 12 is attached to storage tank 11 and conduit 12 includes a first remote end 13a and a second remote end 13b proximate the strip entry side 6 of the mill stand. Each remote end 13a and 13b includes a cryogenic cooling device 14a and 14b that extends across the width of the mill stand or strip at a location suitable for disbursing a controlled amount of cryogen onto the work surfaces of mill stand 1. In some applications, each remote end 13a and 13b is placed at the strip outlet of the roll gap 3 to improve cleaning effects. Although the cryogen delivery system is described as comprising cryogenic cooling devices 14a and 14b, it should be understood that any device suitable for discharging a controlled amount of cryogen onto the work surfaces may be used. For example,

a cryogenic spray bar having an elongated discharge slot that extends across the mill stand width or strip width or a device having an array of individually controlled nozzles could be used.

[0029] In the embodiment shown in Figure 1A, a mill screw 15 that adjusts the mill gap includes a load cell 16a. The mill screw 15 is operated to produce a mill gap required to produce a metallic sheet or strip having predetermined mechanical properties, surface finish, and dimensions, and load cell 16a generates continuous output signals indicative of the roll force. Load cell 16a is connected to a controller 17, for example, a programmable logic controller (PLC) that operates a control valve 18 fitted within conduit 12 at a location between storage tank 11 and the cryogenic cooling devices 14a and 14b. The controller 17 records the output signals from load cell 16a.

[0030] Alternatively, a load cell 16b may be positioned to measure roll force on a bearing 19 that supports the lower backup roll 4b. Similar to load cell 16a, load cell 16b is connected to controller 17, which records the incoming stream of data from load cell 16b.

[0031] The numeric values from load cell 16a and/or 16b are used to determine when control valve 18 should be operated to regulate the mass flow of cryogen from storage tank 11 to mill stand 1, and as implied, cryogen delivery system 10a may include more than one load cell, for example, but not limited to, load cells 16a and 16b whereby controller 17 is programmed to provide averaged numeric values based on a continuous incoming stream of data from multiple load cell measurements.

[0032] Because roll force can be correlated with the thermal conditions existing in the roll stand, and because roll force is influenced by rolling temperature, the roll force measurements are used as feedback signals to accurately regulate the flow of cryogen within a desired mass flow range or at a desired mass flow set point. Accordingly, the discharge intensity of cryogen dispersed onto the work surfaces, or into the roll gap, is controlled in response to the numeric values from the load cell measurements. For example, when the numeric values indicate that the measured roll force is about 15% higher than the roll force absent any cryogen, controller 17 transmits a signal that operates control valve 18 to reduce the mass flow rate of cryogen sprayed or dispersed onto the work surfaces or roll gap until the numeric values return to the preferred range. The adjusted mass flow of cryogen controls the roll force, and thereby regulates rolling temperatures in the mill stand.

[0033] As an alternative to any of the control valves described herein, a throttling gas system could be used to control the mass flow of cryogen. An example of a throttling gas system is provided in U.S. Patent Application No. 11/846,116, filed August 28, 2007, which is incorporated herein by reference as if fully set forth. In a cryogenic cooling device that does not

use a throttling gas, the discharge intensity of the cooling device is primarily a function of the flow rate of cryogen through the cryogenic cooling device. In a cryogenic cooling device that does
5 uses a throttling gas to control discharge intensity, the discharge intensity of the cooling device is a function of both the flow rate of cryogen and throttling gas through the cryogenic cooling device.

[0034] Referring to figure 1B, in this embodiment, the cryogen delivery system 10a is adapted to measure stress conditions on the work roll surface to control the flow of cryogen to the mill stand 1. Cryogenic spray quenching is known to give the effect of causing residual
10 compressive stress conditions on the quenched surfaces. In this embodiment, one or more X-ray analyzers 20a and 20b, capable of determining the stress conditions in the surface of the work rolls 2a, 2b, are used to indicate the amount of stress occurring during the cold rolling operation.

[0035] Output signals indicative of residual stress are generated by analyzers 20a and 20b, and the signals are received as a continuous stream of data by controller 17. Similar to the
15 above roll force measurements, controller 17 uses the numeric values from the incoming stream of data from the analyzers 20a and 20b and operates one or more control valves 18 and 18a in response to a set point value that correlates with a targeted measured stress which, in turn, correlates with desired temperature conditions in mill stand 1 so that the mass flow of liquid nitrogen from storage tank 11 to cryogenic cooling devices 14a and 14b is regulated to disperse
20 a controlled amount of cryogen onto the work surfaces.

[0036] In the present embodiment, shown in Figure 1B, two control valves 18 and 18a are provided. Each control valve communicates with controller 17 so that the cryogen spray from cryogenic cooling devices 14a and 14b can be individually regulated. In addition, as described
25 above, the numeric values can reflect an average of the incoming stream of multiple stress measurements (from multiple x-ray analyzers) to improve accuracy.

[0037] In Figure 1C, at least one sensor 21a and/or 21b is provided in the cryogen delivery system 10a to measure electrical resistance in the work rolls 2a and 2b. Sensors 21a and/or
30 21b can be Ohm meters or any other suitable device known in the art for measuring electrical resistance, and similar to before, the sensors 21a and 21b generate output signals indicative of electrical resistance of the work rolls. Controller 17 receives the incoming stream of data and operates at least one control valve 18 in response to a set point value so that cryogenic cooling devices 14a and 14b disperse a desired controlled amount of cryogen from storage tank 11 onto the work surfaces. The numeric values of the work roll resistance correlate with electrical resistance conditions on the roll which, in turn, correlate with the temperature conditions in mill

stand 1, and the numeric values can either comprise an average of the data transmitted from sensors 21a and 21b or a value based on a single sensor, either 21a or 21b.

[0038] Referring to Figure 1D, at least one sensor 22a and/or 22b is provided in the cryogen delivery system 10a to measure mill speed, for example, the speed of the rotating work rolls 2a and 2b and/or the traveling speed of the rolled product. Sensors 22a and/or 22b may comprise tachometers or any other suitable measuring device known in the art, and similar to before, the sensors 22a and 22b generate output signals indicative of the mill speed. Controller 17 receives the incoming stream of data, and in response to a set point value, operate control valves 18 and 18a so that cryogenic cooling devices 14a and 14b disperse a desired controlled amount of cryogen from storage tank 11 onto the work surfaces.

[0039] In the instance of mill speed measurements, the measured numeric values do not correlate with the temperature conditions in mill stand 1. However, mill speed correlates directly with mill throughput. Therefore, cryogen flow from storage tank 11 to cryogenic cooling devices 14a and 14b can be ratioed, or proportioned/controlled to mill speed in either a directly linear, or even a more complex, empirically-derived function. In addition, the numeric values can either comprise an averaged or individual value based on the data transmitted from multiple sensors, such as sensors 22a and 22b.

[0040] Referring to Figure 1E, sensors that measure different operating parameters are combined in cryogen delivery system 10a to improve accuracy in rolling temperature control. The delivery system includes both X-ray analyzers 20a and 20b to measure residual roll stress and sensors 22a and 22b to measure mill speed. The output signals generated by the different sensors are transmitted to controller 17 which is programmed to combine the incoming stream of data into calculated numeric values. When the calculated value corresponds with a set point value, the controller 17 transmits a signal that operates at least one control valve 18 and/or 18a and a controlled mass flow of cryogen is delivered from storage tank to cryogenic cooling devices 14a and 14b and dispersed onto the work surfaces of mill stand 1.

[0041] Referring to Figures 2A through 2D, the drawings show examples of cryogen delivery systems 10b where each cryogen delivery system 10b has a different non-optical sensor positioned at suitable locations for measuring rolled product parameters. In this set of embodiments, mill stand 1 includes work rolls 2a and 2b, a roll gap 3, preferable but not necessary backup rolls 4a and 4b, and a strip entry side 6 for receiving the rolled product 5.

[0042] Referring to Figure 2A, the cryogen delivery system 10b is similar to the cryogen stand delivery system 10a, and includes storage tank 11 containing a cryogen such as liquid nitrogen or the like, conduit 12 extending to remote ends 13a and 13b proximate the strip entry

side 6, and cryogenic cooling devices 14a and 14b. In some applications, the remote ends 13a and 13b are on the strip outlet to improve cleaning effects. However, in this embodiment, cryogen delivery system 10b includes at least one non-optical sensor that generates an output signal indicative of temperature in the rolled metallic sheet or strip. In this embodiment, the sensors are thermocouples 23a and 23b, however, any suitable, non-optical temperature measuring device known in the art may be used without departing from the scope of the present invention. Controller 17 receives the continuous incoming stream of data from thermocouples 23a and 23b, and is programmed to respond a set point value by transmitting a signal that operates at least one control valve 18 so that cryogenic cooling devices 14a and 14b receive and disperse a controlled mass flow of cryogen from storage tank 11 onto the work surfaces in mill stand 1.

[0043] Referring to Figure 2B, in this embodiment, the cryogen delivery system 10b measures stress conditions in the surface of the rolled metallic sheet or rolled product 5 to provide a desired mass flow of cryogen to mill stand 1. As mentioned above, cryogenic spray quenching is known to give the effect of causing residual compressive stress conditions on the quenched surfaces. Therefore, one or more X-ray analyzers 24a and 24b, capable of determining the stress conditions in the rolled product surface, are positioned on the exit side 6a of the mill stand to indicate the amount of stress that is occurring in rolled product 5 during cold rolling. Output signals indicative of residual stress in the rolled product are generated by analyzers 24a and 24b, and the signals are transmitted as a continuous stream of data to controller 17. Similar to the above stress measurements for roll stand parameters, controller 17 uses the numeric values from the incoming stream of data to operate one or more control valves 18 and 18a in response to a set point value that correlates with temperature conditions in mill stand 1 so that the mass flow of liquid nitrogen from storage tank 11 to cryogenic cooling devices 14a and 14b is accurately regulated to disperse a controlled cryogen spray or flow onto the work surfaces.

[0044] Referring to Figure 2C, in this embodiment, the cryogen delivery system 10b comprises sensors that are capable of measuring strip profile such as shape and flatness. In this embodiment, the sensors comprise X-ray shape gauges 25a and 25b. However, alternate strip profile sensors could include, but are not limited to, tomography gauges, radioisotope traversing gauges, or shape meters where the strip is pulled at an angle over a segmented roll and the segments include transducers capable of measuring the radial forces exerted on them to provide a signal related to strip shape. A wide variety of different devices are available for measuring strip profile and generating output signals that can be used to regulate the mass flow of cryogen from storage tank 11 to cryogenic cooling devices 14a and 14b. In this instance,

gauges 25a and 25b generate output signals indicative of strip profile and transmit the signals to controller 17 where the controller 17 calculates numeric values from the incoming stream of data. When the calculated values correspond to set point values that correlate with mill stand temperature, the controller 17 transmits a signal that operates at least one control valve 18 so that a desired controlled mass flow of liquid nitrogen from storage tank 11 is transferred to cryogenic cooling devices 14a and 14b. The controlled amount of cryogen dispersed onto the work surfaces minimizes shape variations in the rolled product and the relatively constant shape controls mill stand temperature.

[0045] In Figure 2D, the cryogen delivery system 10b includes at least one surface roughness gauge 26a and/or 26b, for example, a contact gauge or laser gauge, to measure roughness or texture (Ra) along the rolled product 5 surface. As above, the gauges 26a and 26b generate output signals indicative of the Ra value along the surface of the rolled product 5.

[0046] Alternatively, a video scanning system, such as surface inspection systems offered by Parsytec AG of Aachen, Germany, could be used to determine roughness. The roughness measurements correlate with thermal conditions and cleanliness of the working rolls existing in a mill stand 1, and controller 17 receives the incoming stream of data whereby the controller 17 calculates the numeric values, and in response to reaching a set point value, the controller 17 operates control valves 18 and 18a so that cryogenic cooling devices 14a and 14b receive a controlled mass flow of cryogen from storage tank 11 that is dispersed onto the work surfaces in mill stand 1 and keeps the working roll surface clean.

[0047] In the embodiment shown in Figure 2E, stress analyzers 24a and/or 24b first shown in Figure 2B are combined with the roughness gauges 26a and 26b of Figure 2D to provided cryogen delivery system 10b having an arrangement of different non-optical sensors to determine different operating parameters in the rolled product 5. The different sensors generate their respective output signals that are combined in controller 17 and the controller 17 is programmed to calculate numeric values based on the combined stream of incoming data. When the calculated values correspond with a predetermined set point value, controller 17 transmits a signal that operates control valves 18 and 18a so that a desired mass flow of cryogen is transmitted from storage tank 11 to cryogenic cooling devices 14a and 14b where the cryogen is dispersed onto the work surfaces in mill stand 1.

[0048] In another set of embodiments, shown in Figures 3A through 3C, are various cryogen delivery systems 10c having additional different sensors suitable for measuring operating parameters associated with the cryogen delivered from storage tank 11. Each cryogen delivery system embodiment 10c includes a mill stand 1 having a pair of opposed work

rolls 2a and 2b, a roll gap 3 set to produce a desired cold rolled metallic sheet or rolled product 5, backup rolls 4a and 4b, and a strip entry side 6.

[0049] Referring in particular to Figure 3A, the cryogen delivery system 10c includes at least one sensor 27a and/or 27b, for example, but not limited to, a thermocouple for measuring condensation 28 in the atmosphere, the condensation created from vapor cooling of humidity proximate the working surfaces receiving cryogen coolant. Sensors 27a and 27b generate output signals indicative of the measured condensate, and controller 17 receives the incoming stream of data. When the received values correspond with a set point value, controller 17 transmits a signal that operates at least one control valve 18 so that cryogenic cooling devices 14a and 14b receive a controlled mass flow of cryogen from storage tank 11 that is dispersed onto the work surfaces in mill stand 1.

[0050] In Figure 3B, the cryogen delivery system 10c includes at least one cryogenic temperature sensor 29 fitted within conduit 12 to measure temperature of the cryogen delivered to cryogenic cooling devices 14a and 14b. Controller 17 receives the stream of incoming temperature measurements. When the temperature values correspond with a set point value rolling temperature in the mill stand, controller 17 transmits a signal that operates at least one control valve 18 so that cryogenic cooling devices 14a and 14b disperse a controlled amount of cryogen onto the work surfaces in mill stand 1.

[0051] Referring to Figure 3C, sensors 27a and 27b that monitor the condensation 28 are combined with the cryogen temperature sensor 29 to provided cryogen delivery system 10c having an arrangement of different sensors to determine different operating parameters associated with the cryogen. The different sensors generate their respective output signals that are combined in controller 17, and the controller 17 is programmed to calculate numeric values based on the combined stream of incoming data. When the calculated values correspond with a predetermined set point value, controller 17 transmits a signal that operates at least one control valve 18 so that a desired mass flow of cryogen is transmitted from storage tank 11 to cryogenic cooling devices 14a and 14b where the cryogen is dispersed onto the work surfaces in mill stand 1.

[0052] Figure 4A shows a cryogen delivery system 10d having sensors for measuring mill stand parameters in combination with sensors for measuring rolled product parameters. In this instance, delivery system 10d includes one or more remotely mounted X-ray analyzers 20a and 20b as disclosed in Figure 1B, and at least one surface roughness gauge 26a and/or 26b as disclosed in Figure 2D. However, it should be understood that any non-optical sensors capable of measuring mill stand parameters and rolled product parameters can be combined in delivery

system 10d without departing from the scope of this invention. The different sensors generate their respective output signals that are combined in controller 17, and the controller 17 is programmed to calculate numeric values from the different streams of incoming data. When the calculated values correspond with a predetermined set point value, controller 17 transmits a signal that operates control valves 18 and 18a so that a controlled mass flow of cryogen is transmitted from storage tank 11 to cryogenic cooling devices 14a and 14b where an accurate amount of cryogen is dispersed onto the work surfaces in mill stand 1.

[0053] Figure 4B shows a cryogen delivery system 10e having sensors for measuring mill stand parameters in combination with sensors for measuring rolled product parameters, and sensors for measuring cryogen parameters. In this instance, delivery system 10e includes one or more remotely mounted X-ray analyzers 20a and 20b, as disclosed in Figure 1B, at least one surface roughness gauge 26a and/or 26b as disclosed in Figure 2D, and at least one cryogenic temperature sensor 29a, 29b as disclosed in Figure 3B. It should be understood that any non-optical sensors capable of measuring mill stand parameters, rolled product parameters, and cryogen parameters can be combined in delivery system 10e without departing from the scope of this invention. The different sensors generate their respective output signals that are combined in controller 17 and the controller 17 is programmed to calculate numeric values from the different streams of incoming data. When the calculated values correspond with a predetermined set point value, controller 17 transmits a signal that operates control valves 18 and 18a so that a desired mass flow of cryogen is transmitted from storage tank 11 to cryogenic cooling devices 14a and 14b where the cryogen is dispersed onto the work surfaces in mill stand 1.

[0054] As such, an invention has been disclosed in terms of preferred embodiments and alternate embodiments thereof, which fulfills each one of the objects of the present invention as set forth above and provides a method and apparatus for controlling rolling temperature in a cold roll mill stand. Of course, various changes, modifications, and alterations from the teachings of the present invention may be contemplated by those skilled in the art without departing from the intended spirit and scope thereof. It is intended that the present invention only be limited by the terms of the appended claims.

CLAIMS:

1. A method comprising:

measuring at least one operating parameter of a cold rolling process, each of the at least one operating parameter being correlated to the thermal conditions of a rolled material of the cold rolling process; and

controlling operation of a cryogenic cooling device based at least in part on measurements of the at least one operating parameter.

2. The method of claim 1, wherein the controlling step comprises setting a cryogenic discharge intensity of the cryogenic cooling device based at least in part on measurements of the at least one operating parameter.

3. The method of claim 2, further comprising associating a value with each measurement of the at least one operating parameter, wherein the controlling step further comprises adjusting the cryogenic discharge intensity of the cryogenic cooling device to bring the value into a predetermined range if the value falls outside of the predetermined range.

4. The method of claim 1, wherein the measuring step comprises measuring the at least one operating parameter of the cold rolling process, each of the at least one operating parameter being correlated to the thermal conditions of a surface of the rolled material.

5. The method of claim 1, wherein the measuring step comprises measuring the at least one operating parameter of the cold rolling process, each of the at least one operating parameter being selected from the group consisting of electrical resistance on a surface of a roll, stress on the surface of the roll, and roughness of the surface of the roll.

6. The method of claim 1, wherein the measuring step comprises measuring the at least one operating parameter of the cold rolling process, each of the at least one operating parameter being selected from the group consisting of electrical resistance on a surface of a rolled material, stress on the surface of the rolled material, thickness of the rolled material, and flatness of the rolled material.

7. The method of claim 1, wherein the measuring step comprises measuring a temperature of a rolled material using a non-optical sensor.
8. The method of claim 1, wherein the controlling step comprises controlling operation of a cryogenic spray device based at least in part on measurements of the at least one operating parameter.
9. The method of claim 1, wherein the controlling step comprises controlling operation of a cryogenic cooling device based at least in part on averaged numerical values calculated from measurements of the at least one operating parameter.
10. The method of claim 1, wherein the measuring step comprises continuously measuring at least one operating parameter of the cold rolling process.
11. An apparatus for use with a cold rolling process, the apparatus comprising:
at least one sensor, each of the at least one sensor being adapted to measure an operating parameter of the cold rolling process, the operating parameter being correlated to the thermal conditions of an element of the cold rolling process;
a cryogenic cooling device having an adjustable discharge intensity; and
a controller that is configured to receive output signals received from the at least one sensor and is programmed to adjust the discharge intensity of the cryogenic cooling device based at least in part on the output signals received from the at least one sensor.
12. The apparatus of claim 11 wherein the controller is programmed to convert the output signals into values and is programmed to adjust the cryogenic discharge intensity of the cryogenic device to bring the values into a predetermined range if the values fall outside of the predetermined range.
13. The apparatus of claim 11, wherein the operating parameter is selected from the group consisting of a rolled material and a work roll.

14. The apparatus of claim 11, wherein the operating parameter is selected from the group consisting of electrical resistance on a surface of a roll, stress on the surface of the roll, and roughness of the surface of the roll.

5 15. The apparatus of claim 11, wherein the operating parameter is selected from the group consisting of electrical resistance on a surface of a rolled material, stress on the surface of the rolled material, thickness of the rolled material, and flatness of the rolled material.

10 16. The apparatus of claim 11, wherein the operating parameter comprises load force on a work roll used in the cold rolling process.

17. The apparatus of claim 11, wherein the controller is programmed to calculate average values from the output signals and adjust the discharge intensity of the cryogenic cooling device based at least in part on the average values.

15

18. The apparatus of claim 11, wherein the at least one sensor is adapted to continuously measure the operating parameter.

19. A method comprising:

20

measuring a load force acting on a roll of a cold rolling process;

controlling operation of a cryogenic cooling device based at least in part on measurements of the load force.

25 20. The method of claim 19, wherein the measuring step comprises measuring a load force acting on a roll of a cold rolling process based on an output signal of at least one load cell.

AMENDED CLAIMS

[received by the International Bureau on 19 January 2009 (19.01.09)]

1. A method comprising:
measuring at least one operating parameter of a cold rolling process, each of the at least one
operating parameter being correlated to the thermal conditions of a rolled material of the cold rolling
5 process; and
adjusting the discharge intensity of at least a portion of a cryogenic cooling device based at least
in part on measurements of the at least one operating parameter.
2. The method of claim 1, wherein the adjusting step comprises setting a cryogenic discharge
10 intensity of the cryogenic cooling device based at least in part on measurements of the at least one
operating parameter.
3. The method of claim 2, further comprising associating a value with each measurement of the at
least one operating parameter, wherein the adjusting step further comprises adjusting the cryogenic
15 discharge intensity of the cryogenic cooling device to bring the value into a predetermined range if the
value falls outside of the predetermined range.
4. The method of claim 1, wherein the measuring step comprises measuring the at least one
operating parameter of the cold rolling process, each of the at least one operating parameter being
20 correlated to the thermal conditions of a surface of the rolled material.
5. The method of claim 1, wherein the measuring step comprises measuring the at least one
operating parameter of the cold rolling process, each of the at least one operating parameter being
selected from the group consisting of electrical resistance on a surface of a roll, stress on the
25 surface of the roll, and roughness of the surface of the roll.
6. The method of claim 1, wherein the measuring step comprises measuring the at least one
operating parameter of the cold rolling process, each of the at least one operating parameter being
selected from the group consisting of electrical resistance on a surface of a rolled material, stress on
the surface of the rolled material, thickness of the rolled material, and flatness of the rolled material.

7. The method of claim 1, wherein the measuring step comprises measuring a temperature of a rolled material using a non-optical sensor.
- 5 8. The method of claim 1, wherein the adjusting step comprises controlling operation of a cryogenic spray device based at least in part on measurements of the at least one operating parameter.
9. The method of claim 1, wherein the adjusting step comprises controlling operation of a cryogenic cooling device based at least in part on averaged numerical values calculated from
10 measurements of the at least one operating parameter.
10. The method of claim 1, wherein the measuring step comprises continuously measuring at least one operating parameter of the cold rolling process.
- 15 11. An apparatus for use with a cold rolling process, the apparatus comprising:
at least one sensor, each of the at least one sensor being adapted to measure an operating parameter of the cold rolling process, the operating parameter being correlated to the thermal conditions of an element of the cold rolling process;
a cryogenic cooling device having an adjustable discharge intensity; and
20 a controller that is configured to receive output signals received from the at least one sensor and is programmed to adjust the discharge intensity of the cryogenic cooling device based at least in part on the output signals received from the at least one sensor.
- 25 12. The apparatus of claim 11 wherein the controller is programmed to convert the output signals into values and is programmed to adjust the cryogenic discharge intensity of the cryogenic device to bring the values into a predetermined range if the values fall outside of the predetermined range.
13. The apparatus of claim 11, wherein the operating parameter is selected from the group

consisting of a rolled material and a work roll.

5 14. The apparatus of claim 11, wherein the operating parameter is selected from the group consisting of electrical resistance on a surface of a roll, stress on the surface of the roll, and roughness of the surface of the roll.

10 15. The apparatus of claim 11, wherein the operating parameter is selected from the group consisting of electrical resistance on a surface of a rolled material, stress on the surface of the rolled material, thickness of the rolled material, and flatness of the rolled material.

16. The apparatus of claim 11, wherein the operating parameter comprises load force on a work roll used in the cold rolling process.

15 17. The apparatus of claim 11, wherein the controller is programmed to calculate average values from the output signals and adjust the discharge intensity of the cryogenic cooling device based at least in part on the average values.

18. The apparatus of claim 11, wherein the at least one sensor is adapted to continuously measure the operating parameter.

20

19. A method comprising:
measuring a load force acting on a roll of a cold rolling process; and
adjusting the discharge intensity of at least a portion of a cryogenic cooling device based at least in part on measurements of the load force.

25

20. The method of claim 19, wherein the measuring step comprises measuring a load force acting on a roll of a cold rolling process based on an output signal of at least one load cell.

Statement under Article 19(1)

Claims 1-3, 8-9, and 19 have been amended. Claims 4-7, 10-18, and 20 are unchanged. After replacing the claims as set forth above, claims 1-20 are now pending in this application.

Claims 1 and 19 have been amended to more clearly define over U.S. Patent No. 4,392,367 to Bald and U.S. Patent No. 6,675,622 to Plicht et al., both of which were cited as "Y" references in the International Search Report (ISR) mailed on November 17, 2008.

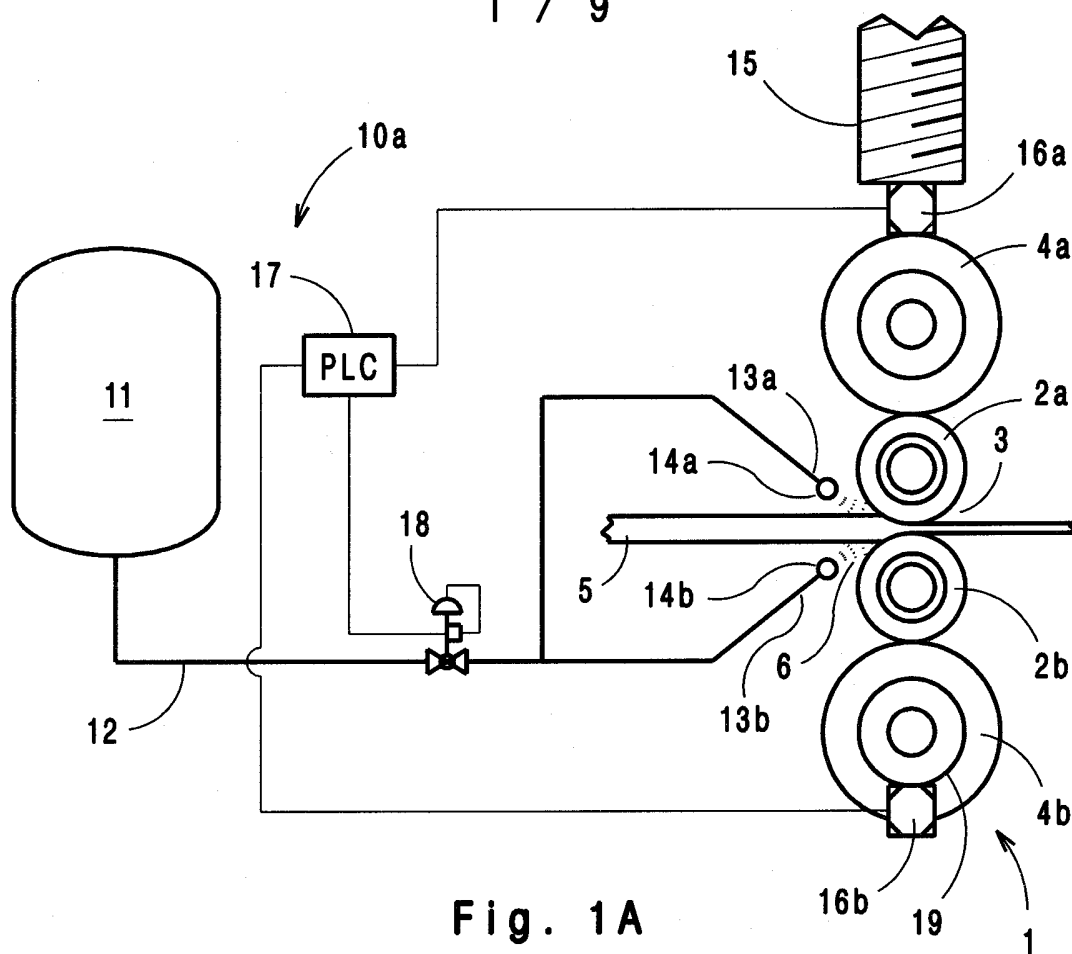

Fig. 1A

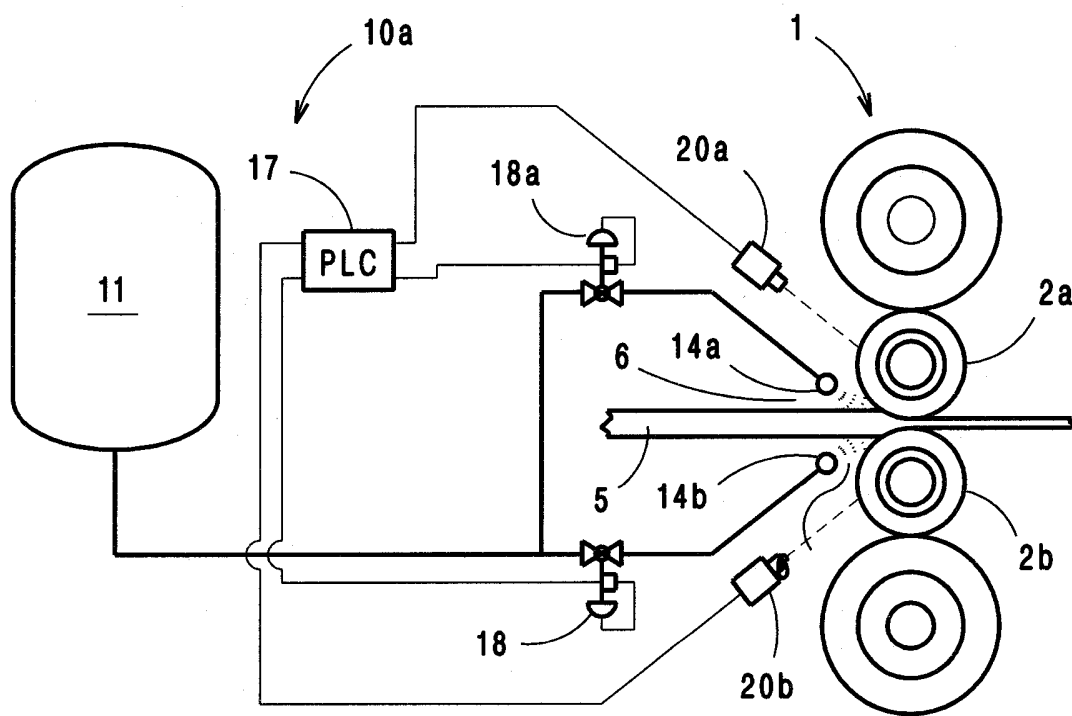
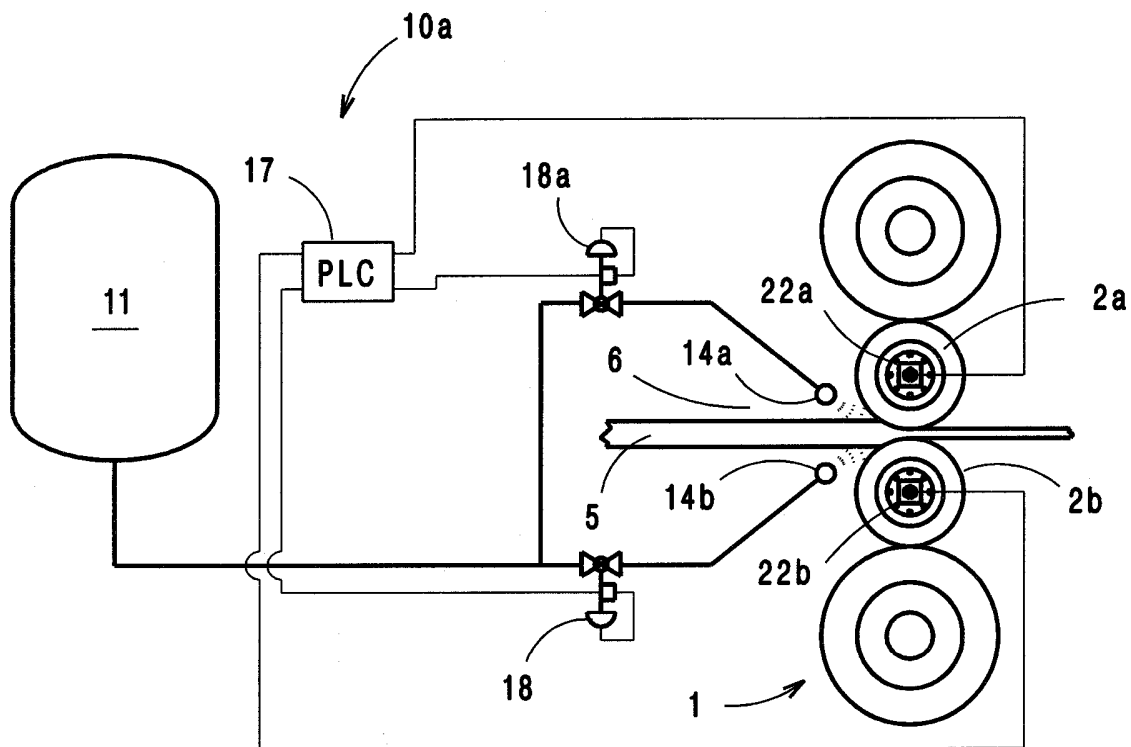
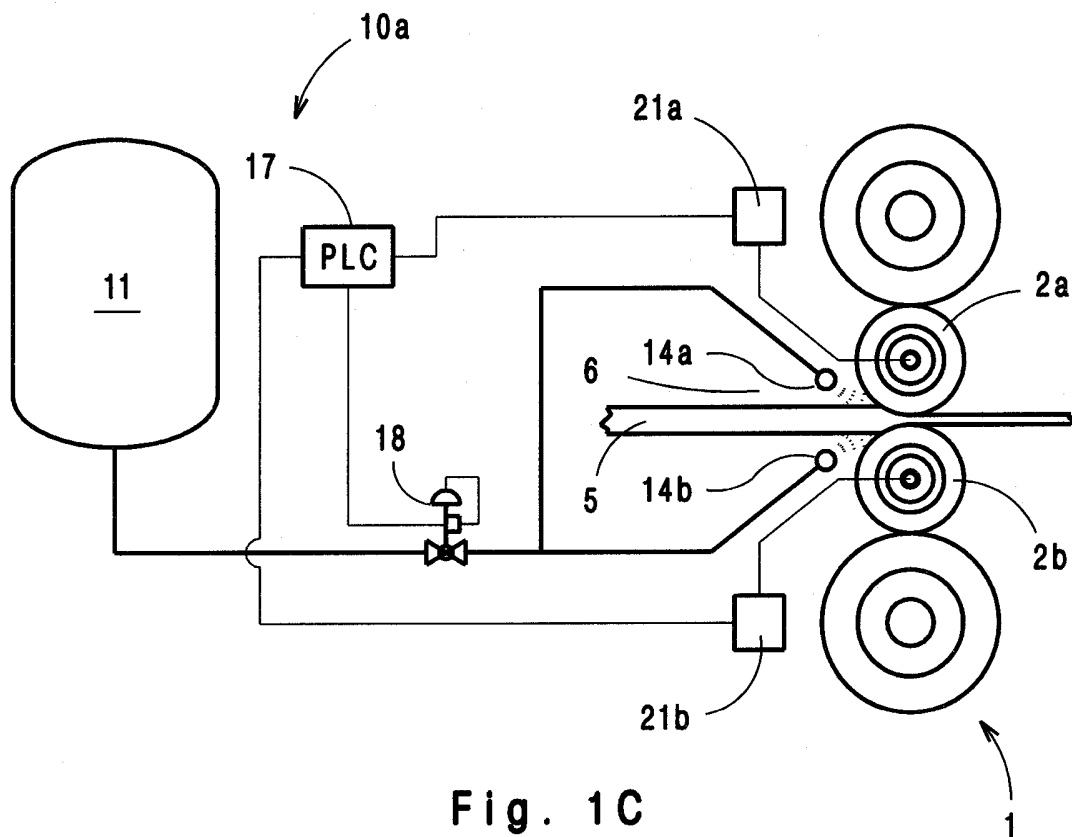

Fig. 1B



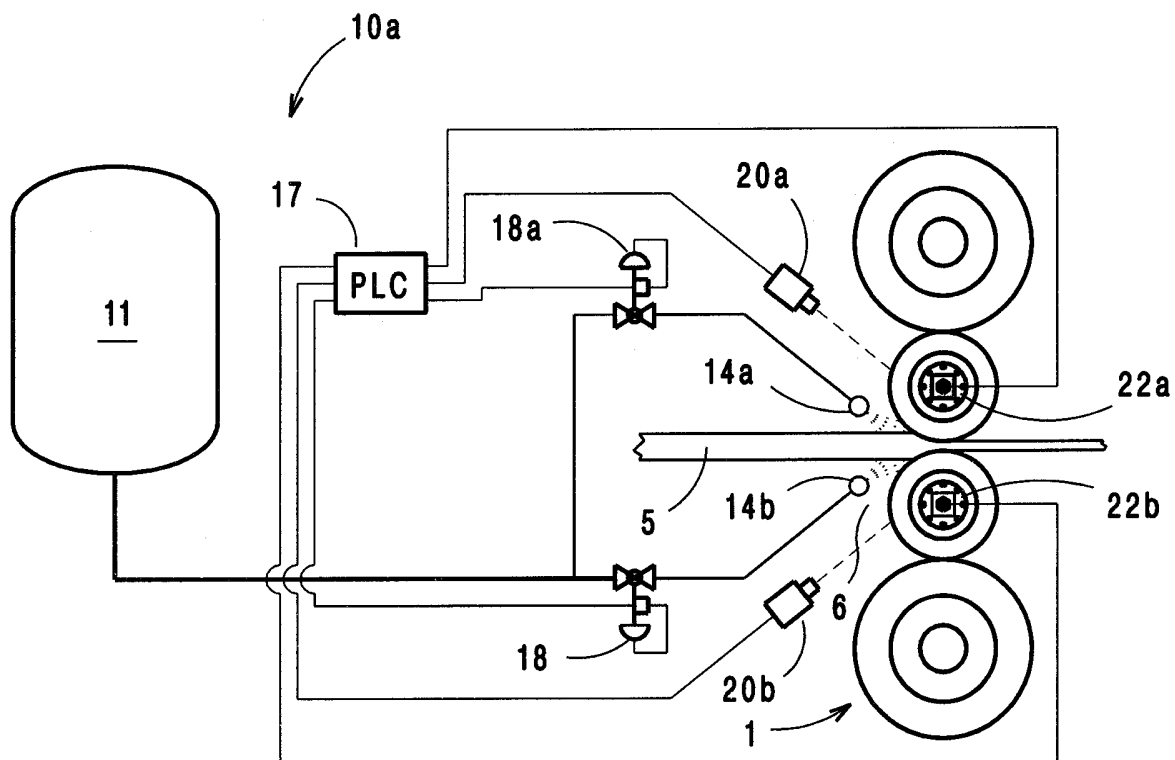

Fig. 1E

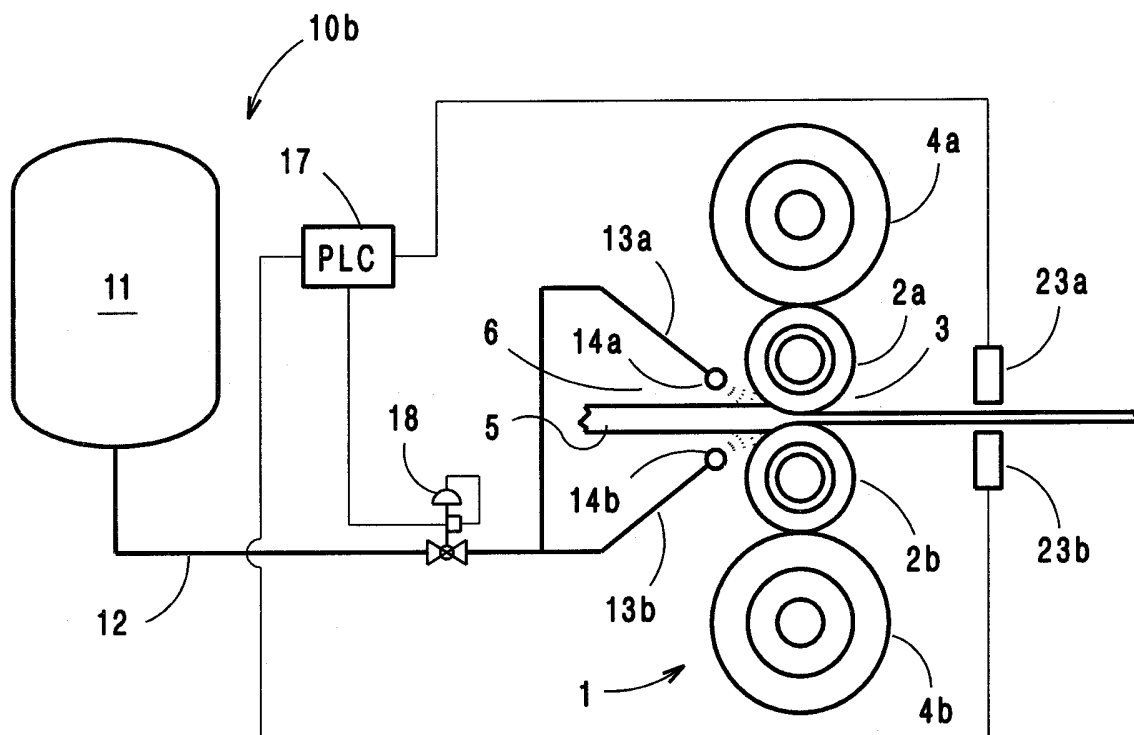

Fig. 2A

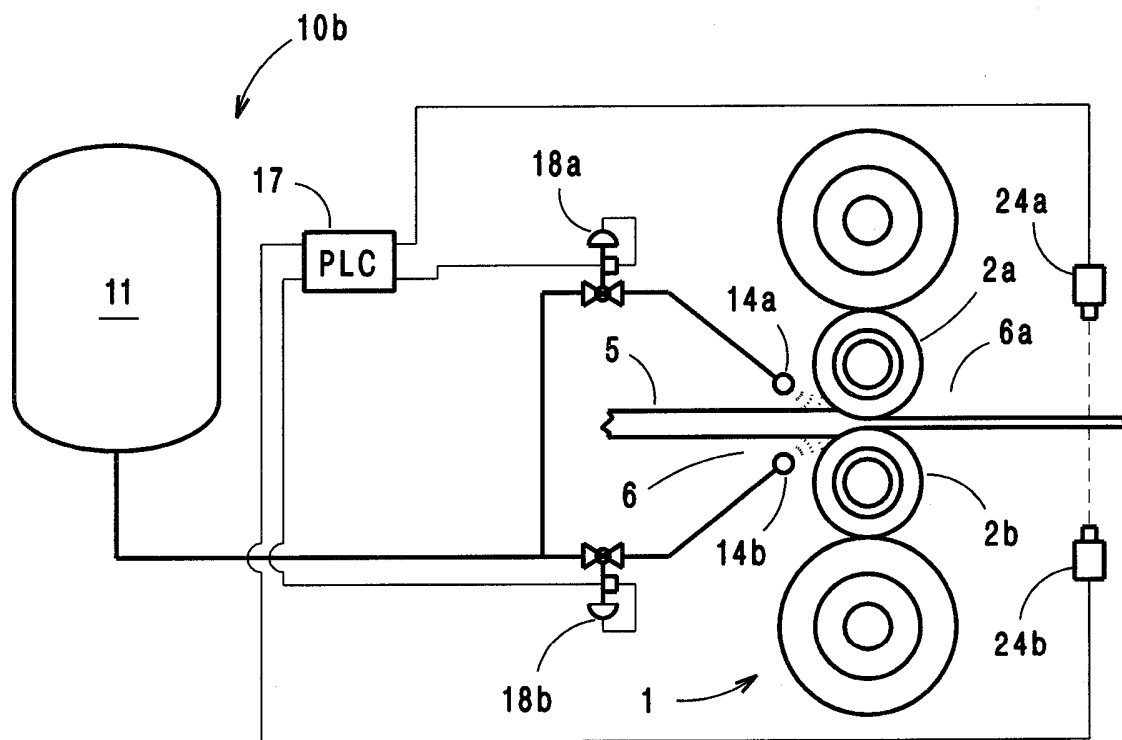

Fig. 2B

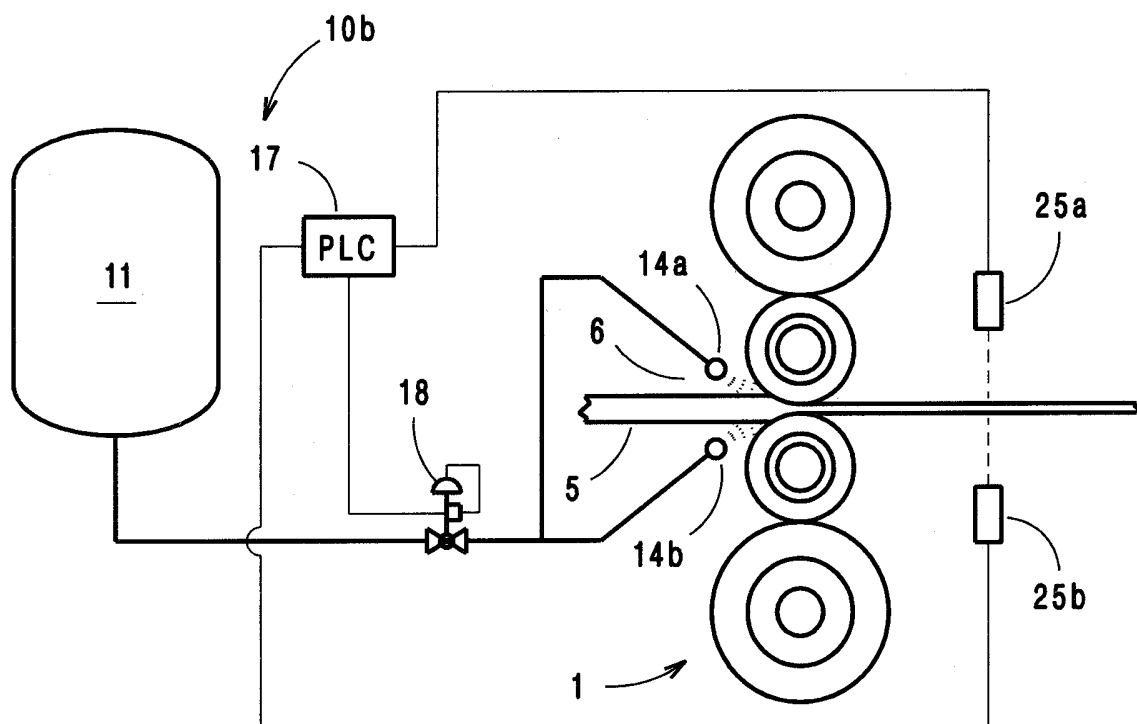

Fig. 2C

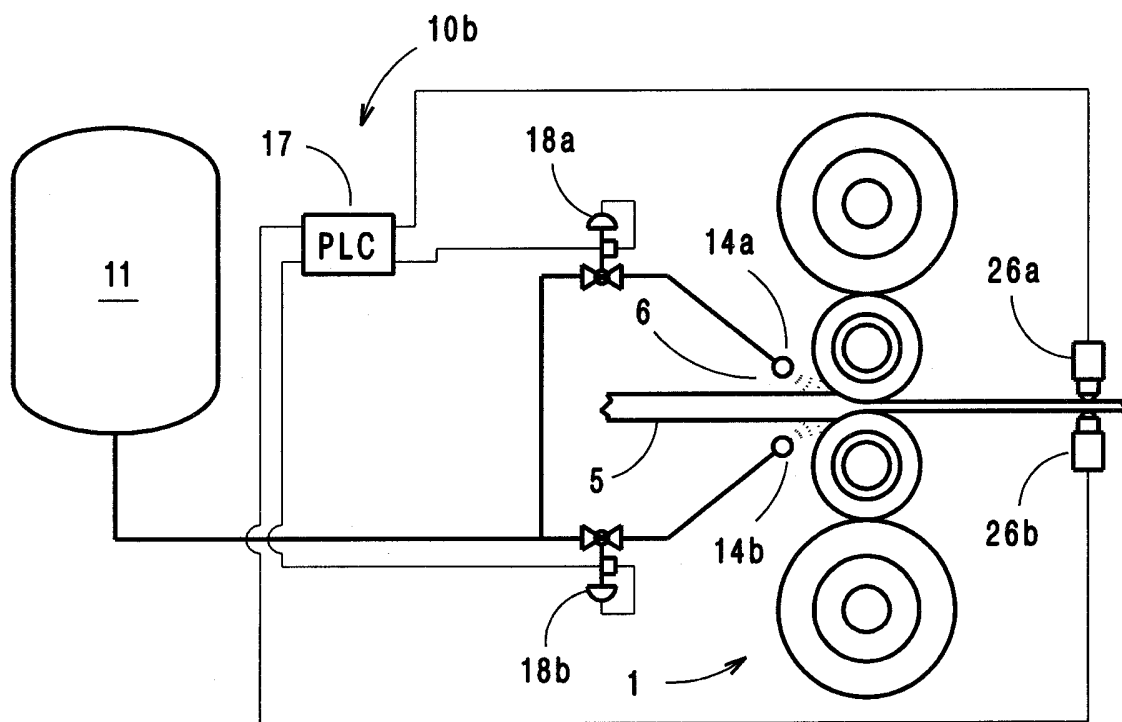

Fig. 2D

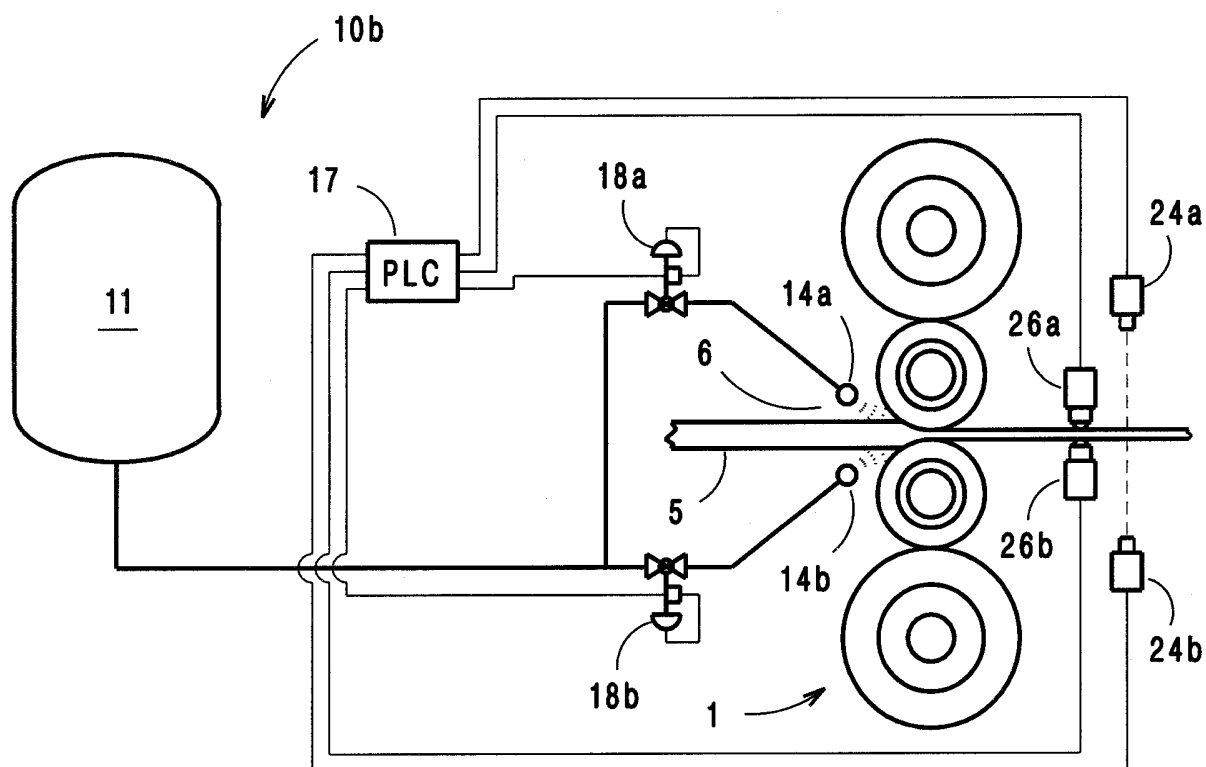

Fig. 2E

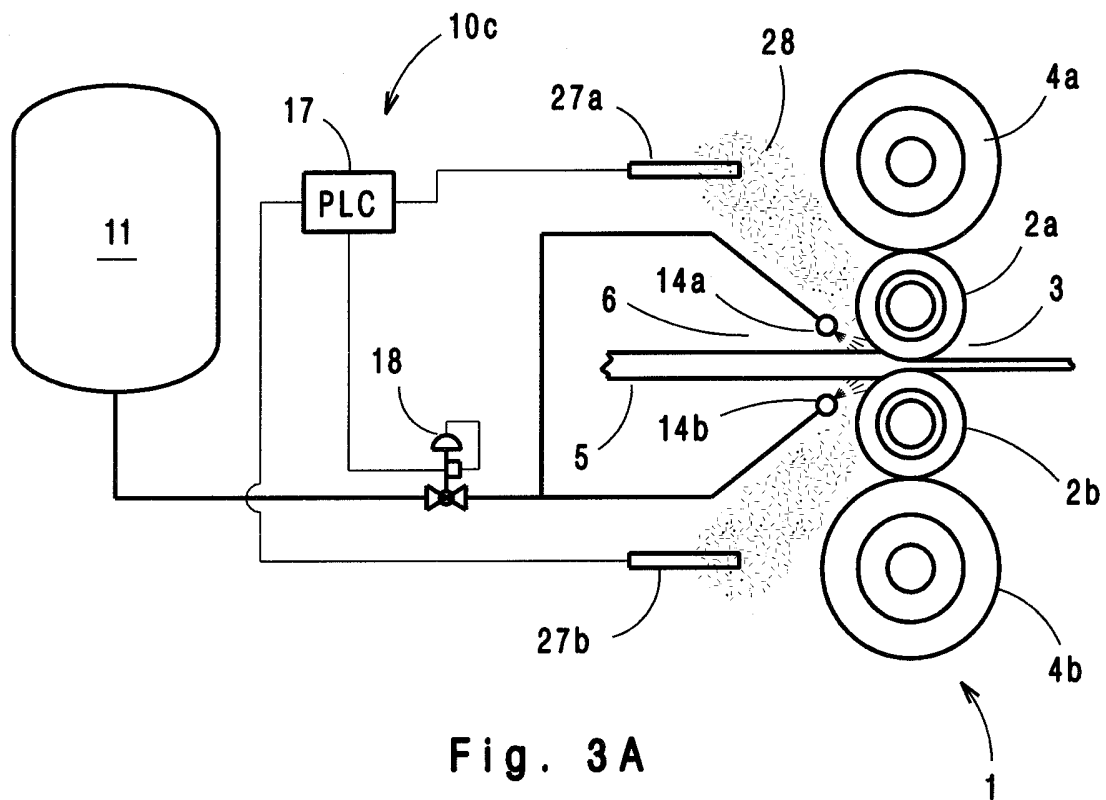

Fig. 3A

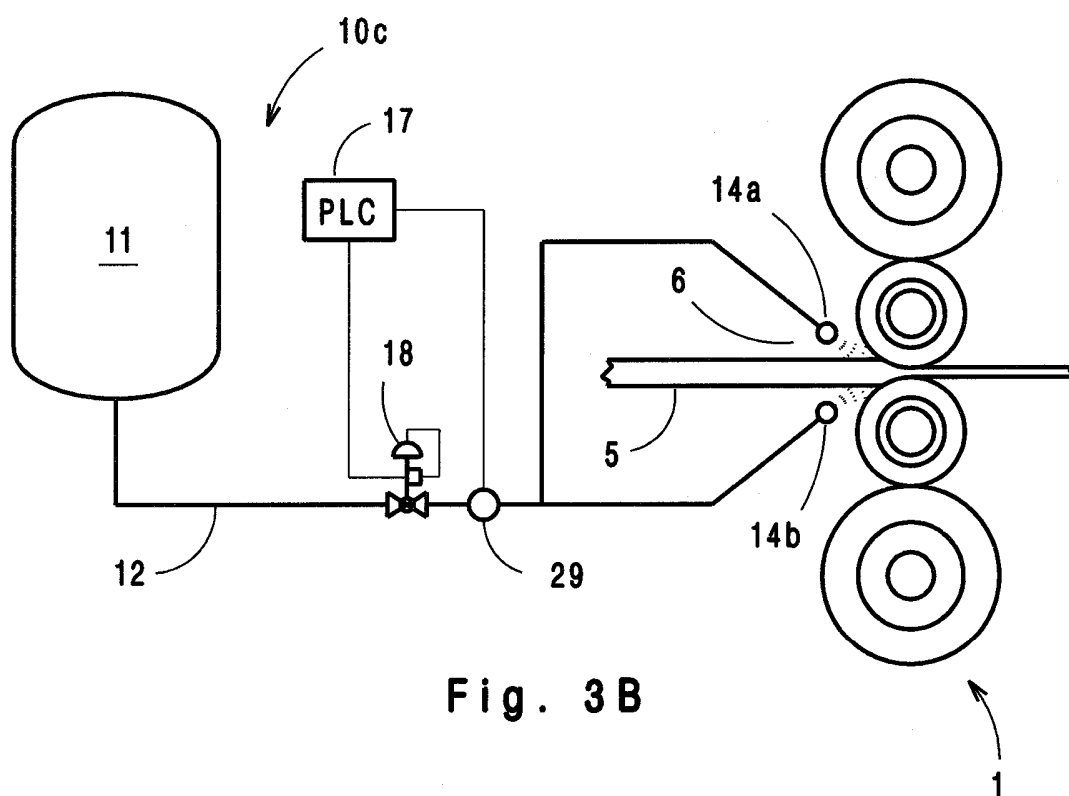

Fig. 3B

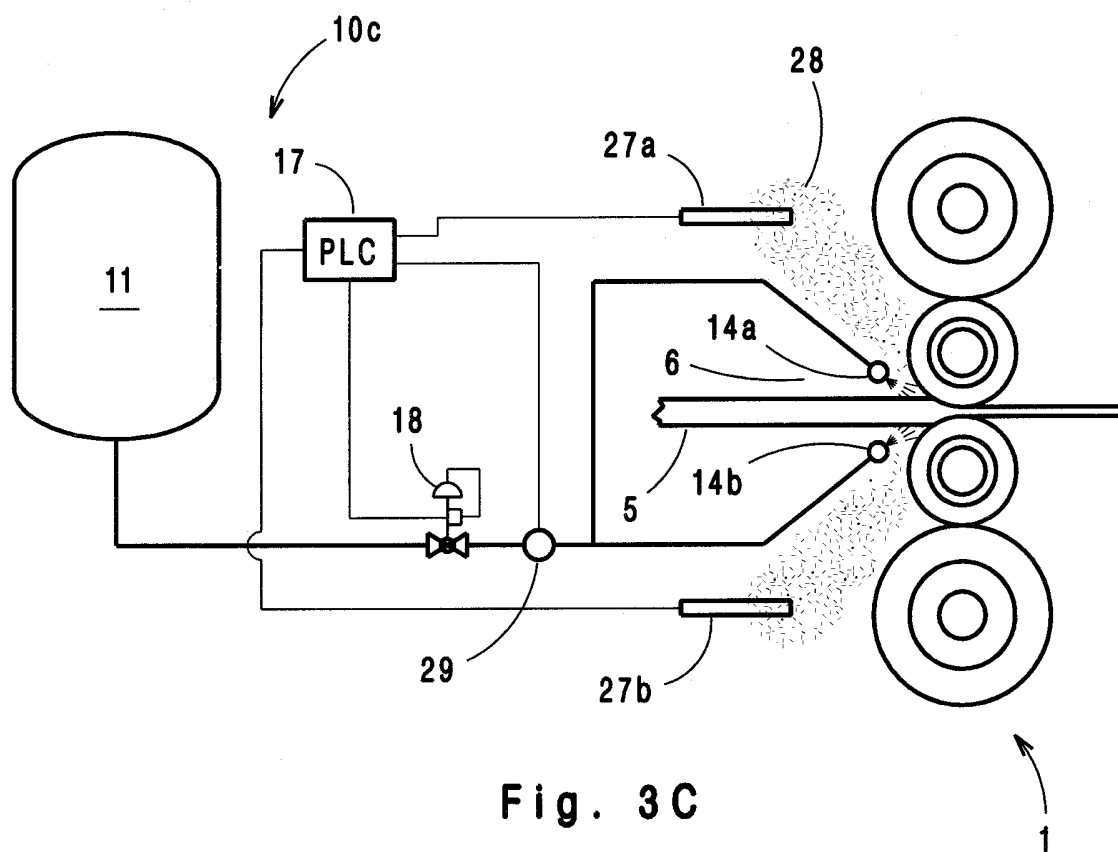

Fig. 3C

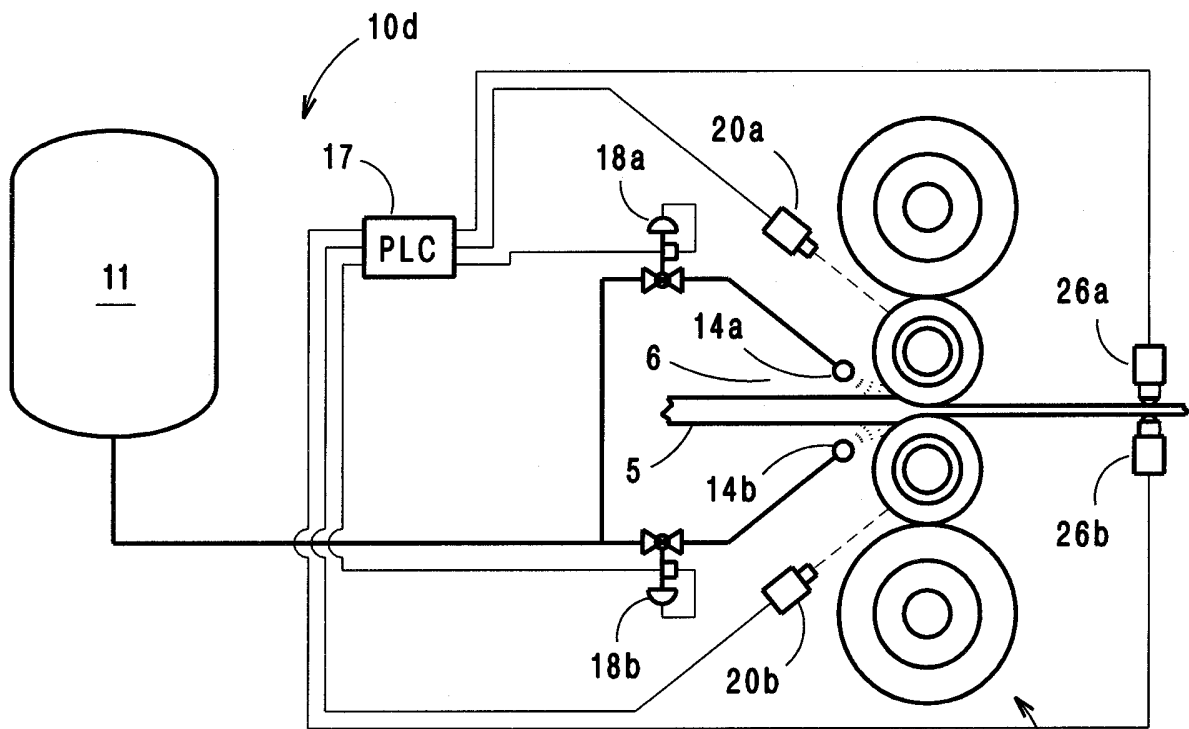

Fig. 4A

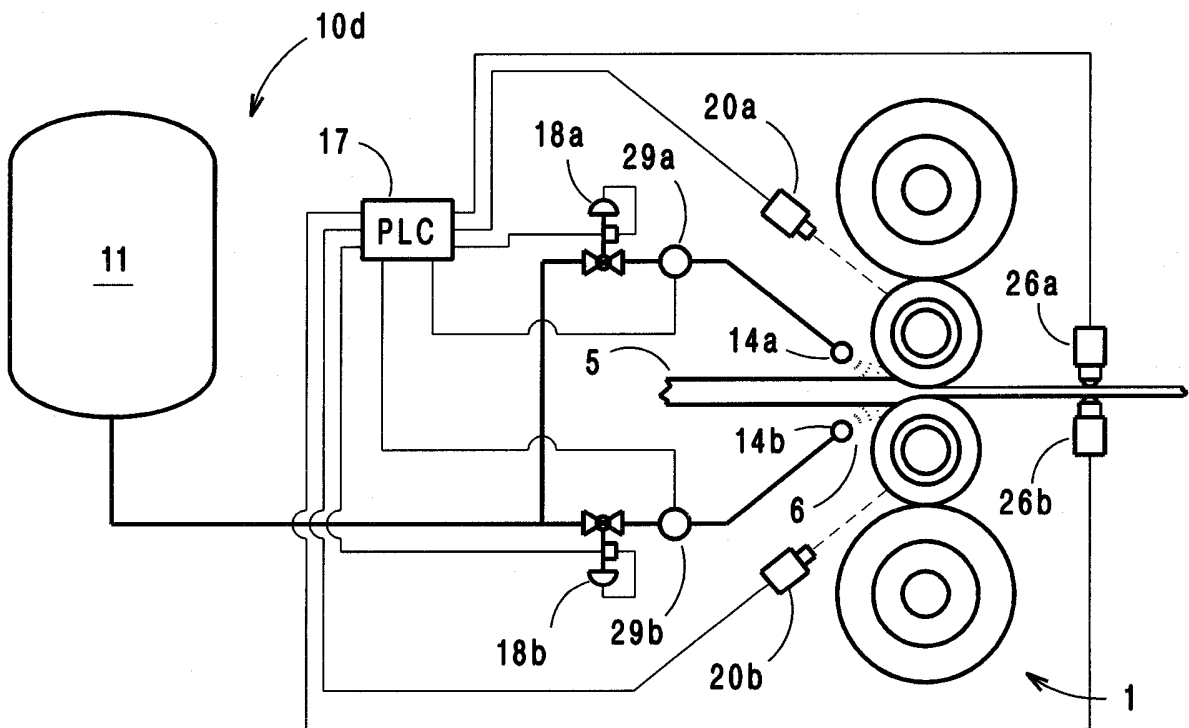

Fig. 4B

INTERNATIONAL SEARCH REPORT

International application No.

PCT/US 08/74451

A. CLASSIFICATION OF SUBJECT MATTER IPC(8) - B21B 27/06 (2008.04) USPC - 72/202 According to International Patent Classification (IPC) or to both national classification and IPC		
B. FIELDS SEARCHED Minimum documentation searched (classification system followed by classification symbols) IPC(8) - B21B 27/06 (2008.04) USPC - 72/202 Documentation searched other than minimum documentation to the extent that such documents are included in the fields searched USPC - 72/200, 201, 202, 342.2, 38 -- term limited -- Electronic data base consulted during the international search (name of data base and, where practicable, search terms used) PubWEST(US Pre-Grant Publication Full-Text, US Patents Full-Text, EPO and JPO Abstracts); Google Scholar Terms: process control, load cell, mill stand, output signal, parameter, variable, sensor, "electrical resistance", stress, strain, thickness, flatness, roughness), cryogenic, sensor, flow, cooling, temperature, measure		
C. DOCUMENTS CONSIDERED TO BE RELEVANT		
Category*	Citation of document, with indication, where appropriate, of the relevant passages	Relevant to claim No.
Y	US 4,392,367 A (Bald) 12 July 1983 (12.07.1983), (col 1 ln 35-40, col 2 ln 18-30 and ln 37-51, col 5 ln 35-60, col 6 ln 18-40)	1-20
Y	US 6,675,622 B2 (Plicht et al.) 13 January 2004 (13.01.2004), (col 1 ln 50-60, col 2 ln 20-25, col 3 ln 48-52)	1-20
<input type="checkbox"/> Further documents are listed in the continuation of Box C. <input type="checkbox"/>		
* Special categories of cited documents: "A" document defining the general state of the art which is not considered to be of particular relevance "E" earlier application or patent but published on or after the international filing date "L" document which may throw doubts on priority claim(s) or which is cited to establish the publication date of another citation or other special reason (as specified) "O" document referring to an oral disclosure, use, exhibition or other means "P" document published prior to the international filing date but later than the priority date claimed "T" later document published after the international filing date or priority date and not in conflict with the application but cited to understand the principle or theory underlying the invention "X" document of particular relevance; the claimed invention cannot be considered novel or cannot be considered to involve an inventive step when the document is taken alone "Y" document of particular relevance; the claimed invention cannot be considered to involve an inventive step when the document is combined with one or more other such documents, such combination being obvious to a person skilled in the art "&" document member of the same patent family		
Date of the actual completion of the international search 29 October 2008 (29.10.2008)		Date of mailing of the international search report 17 NOV 2008
Name and mailing address of the ISA/US Mail Stop PCT, Attn: ISA/US, Commissioner for Patents P.O. Box 1450, Alexandria, Virginia 22313-1450 Facsimile No. 571-273-3201		Authorized officer: Lee W. Young PCT Helpdesk: 571-272-4300 PCT OSP: 571-272-7774